

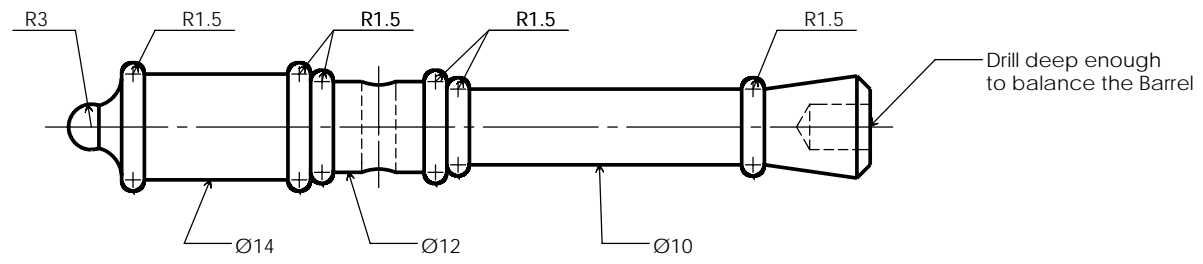

Name : \_\_\_\_\_

Part	Complete
1	
2	
3	
4	
5	
6	
7	
8	
9	
10	
11	

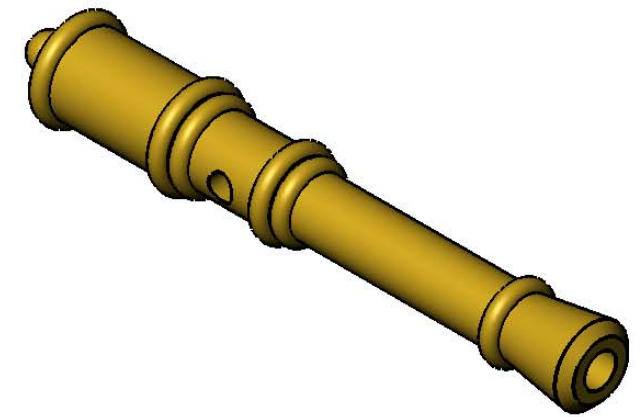

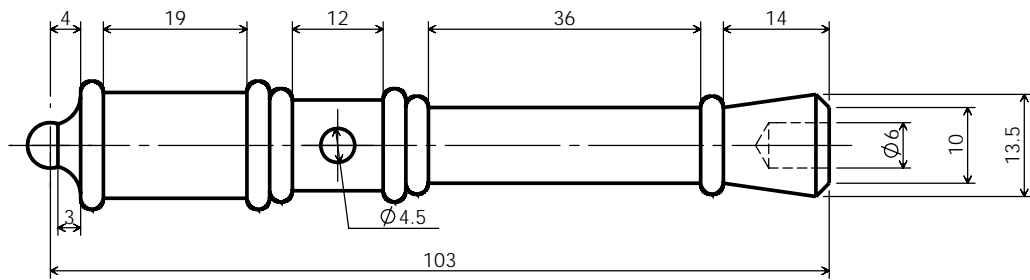

The Cannon	J.C.
PracticalStudent.com	
Part Number : 1	
Part Name : Barrel	
Material : Brass or Steel	A4
	2/8/07
Required : 1	Drawing 1 of 1

Before Starting

Tools for Marking Out :

Tools for Manufacturing :

Skill I am going to concentrate on :

After completion

Marking Accuracy	Poor	Medium	Good
Hacksawing & Filing Quality	Poor	Medium	Good
Surface Finish	Poor	Medium	Good

What did I do well :

What do I need to improve on :

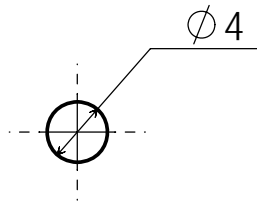
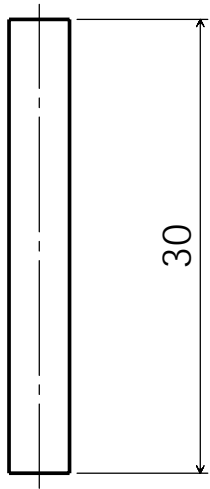

The Cannon	J.C.
PracticalStudent.com	
Part Number : 2 Part Name : Trunnion	
Material : Brass or Steel	A4
	2/8/07
Required : 1	Drawing 1 of 1

Before Starting

Tools for Marking Out :

Tools for Manufacturing :

Skill I am going to concentrate on :

After completion

Marking Accuracy	Poor	Medium	Good
Hacksawing & Filing Quality	Poor	Medium	Good
Surface Finish	Poor	Medium	Good

What did I do well :

What do I need to improve on :

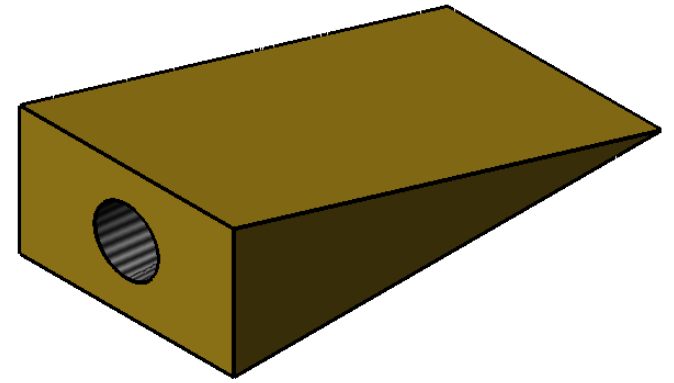
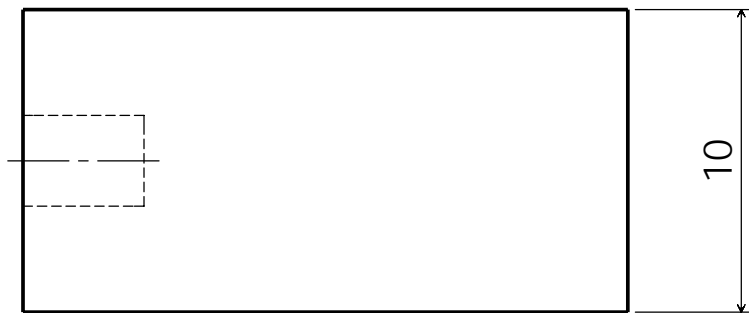
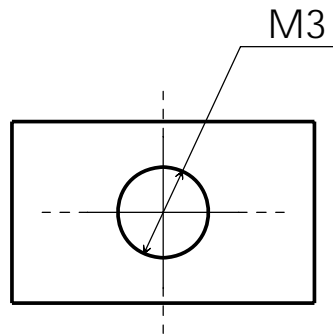
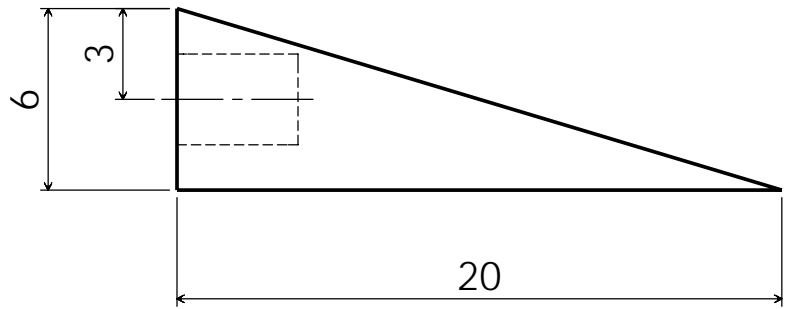

The Cannon	J.C.
PracticalStudent.com	
Part Number : 3	
Part Name : Wedge	
Material : Brass or Steel	A4
Required : 1	2/8/07
Drawing 1 of 1	

Before Starting

Tools for Marking Out :

Tools for Manufacturing :

Skill I am going to concentrate on :

After completion

Marking Accuracy	Poor	Medium	Good
Hacksawing & Filing Quality	Poor	Medium	Good
Surface Finish	Poor	Medium	Good

What did I do well :

What do I need to improve on :



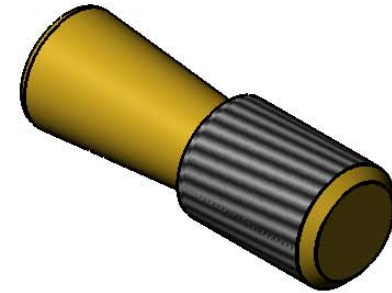
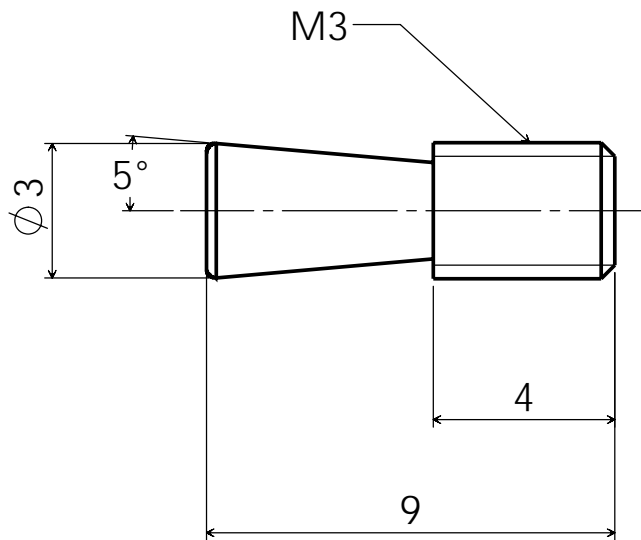

The Cannon	J.C.
PracticalStudent.com	
Part Number : 4	
Part Name : Wedge Handle	
Material : Brass or Steel	A4
	2/8/07
Required : 1	Drawing 1 of 1

Before Starting

Tools for Marking Out :

Tools for Manufacturing :

Skill I am going to concentrate on :

After completion

Marking Accuracy	Poor	Medium	Good
Hacksawing & Filing Quality	Poor	Medium	Good
Surface Finish	Poor	Medium	Good

What did I do well :

What do I need to improve on :

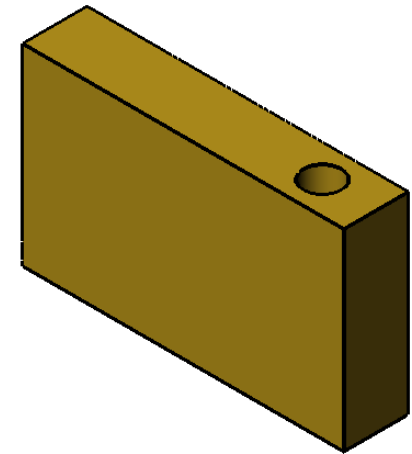
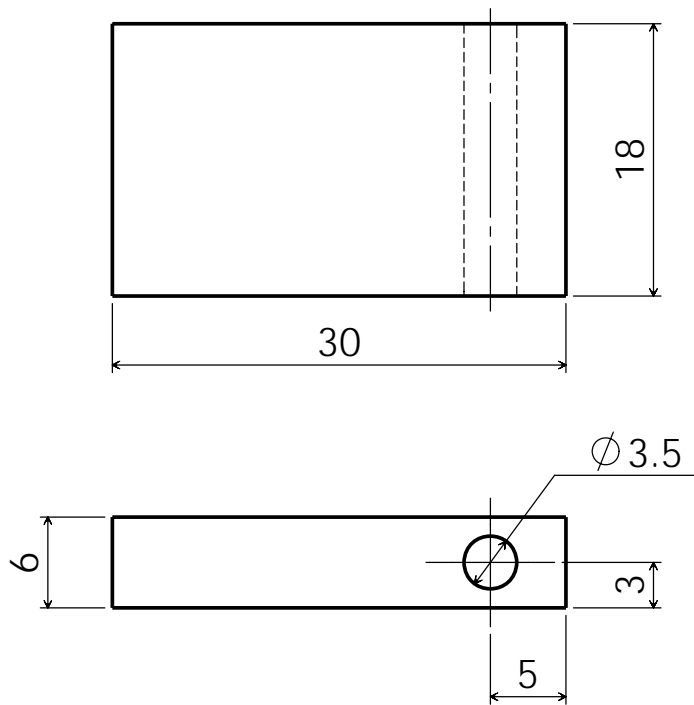

The Cannon	J.C.
PracticalStudent.com	
Part Number : 5	
Part Name : Platform	
Material : Brass or Steel	A4
Required : 1	2/8/07
Drawing 1 of 1	

Before Starting

Tools for Marking Out :

Tools for Manufacturing :

Skill I am going to concentrate on :

After completion

Marking Accuracy	Poor	Medium	Good
Hacksawing & Filing Quality	Poor	Medium	Good
Surface Finish	Poor	Medium	Good

What did I do well :

What do I need to improve on :

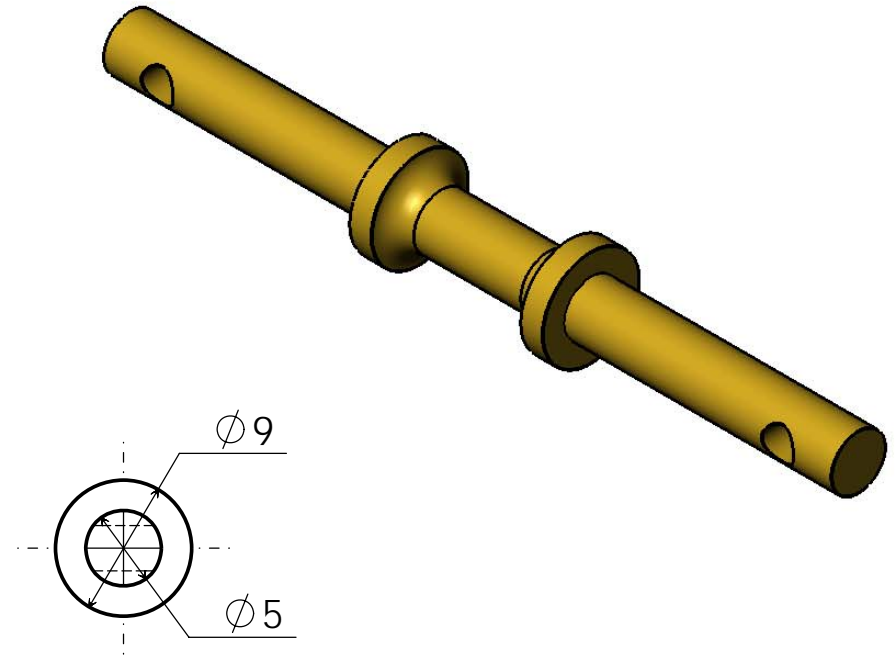
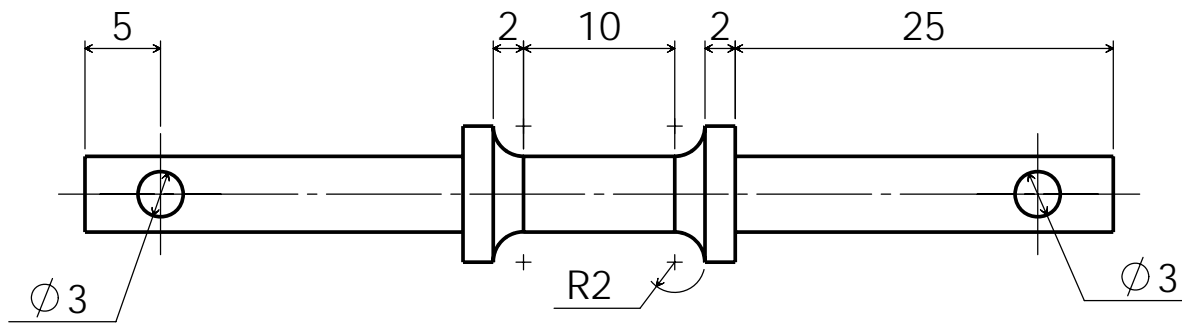

The Cannon	J.C.
PracticalStudent.com	
Part Number : 6	
Part Name : Axle	
Material : Brass or Steel	A4
	2/8/07
Required : 1	Drawing 1 of 1

Before Starting

Tools for Marking Out :

Tools for Manufacturing :

Skill I am going to concentrate on :

After completion

Marking Accuracy	Poor	Medium	Good
Hacksawing & Filing Quality	Poor	Medium	Good
Surface Finish	Poor	Medium	Good

What did I do well :

What do I need to improve on :

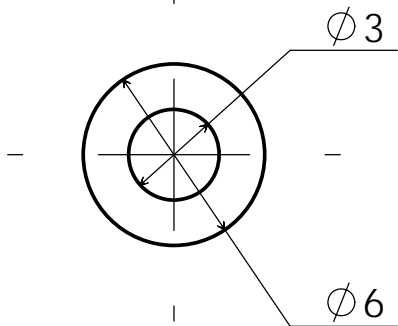
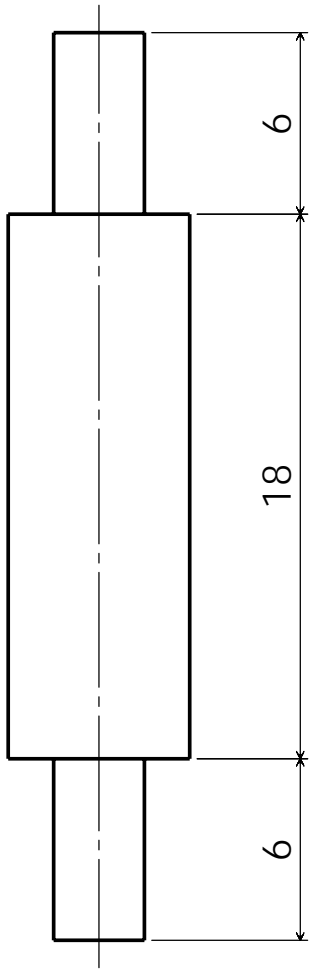

The Cannon	J.C.
PracticalStudent.com	
Part Number : 7	
Part Name : Tie Rod	
Material : Brass or Steel	A4
Required : 2	2/8/07
Drawing 1 of 1	

Before Starting

Tools for Marking Out :

Tools for Manufacturing :

Skill I am going to concentrate on :

After completion

Marking Accuracy	Poor	Medium	Good
Hacksawing & Filing Quality	Poor	Medium	Good
Surface Finish	Poor	Medium	Good

What did I do well :

What do I need to improve on :



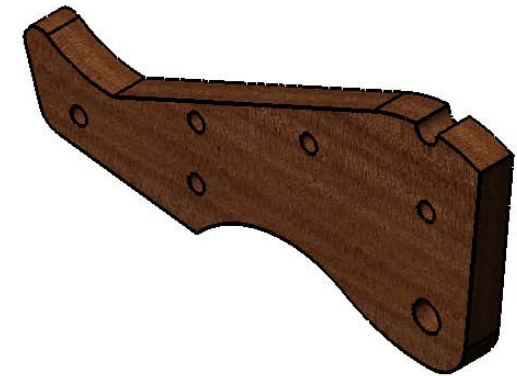
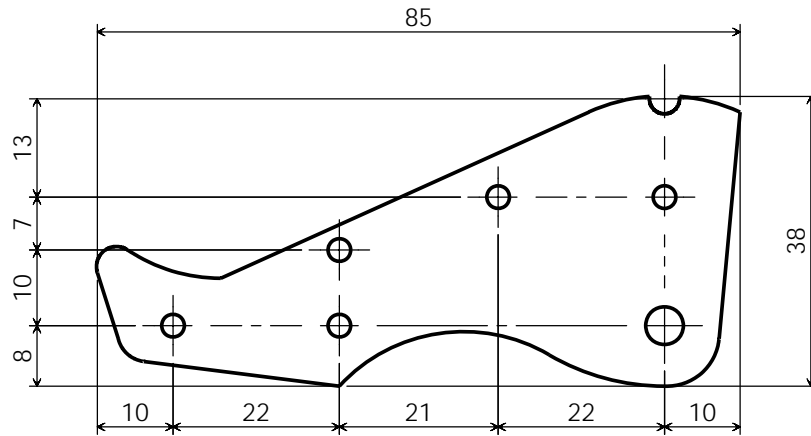

The outline can be your own design but it should fit inside an 85mm X 38mm rectangle



The Cannon	J.C.
PracticalStudent.com	
Part Number : 8	
Part Name : Side	
Material : Hard Wood	A4
	2/8/07
Required : 2	Drawing 1 of 1

Before Starting

Tools for Marking Out :

Tools for Manufacturing :

Skill I am going to concentrate on :

After completion

Marking Accuracy	Poor	Medium	Good
Hacksawing & Filing Quality	Poor	Medium	Good
Surface Finish	Poor	Medium	Good

What did I do well :

What do I need to improve on :

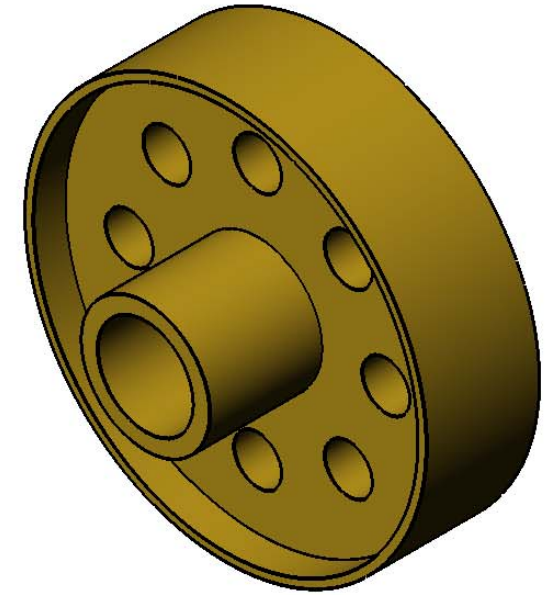
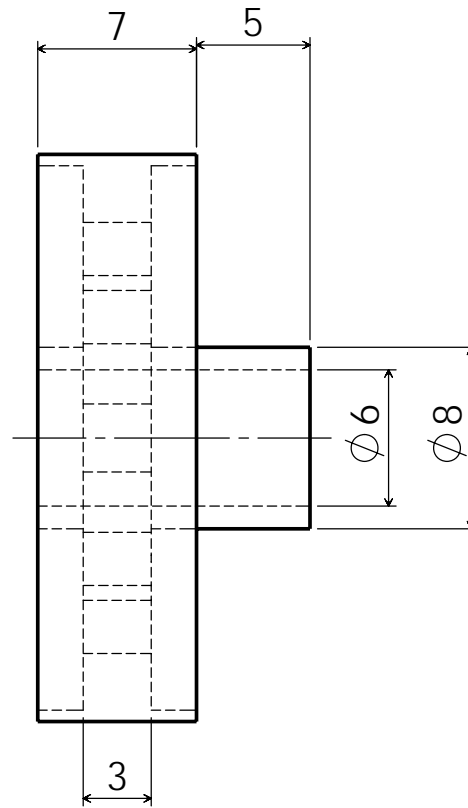
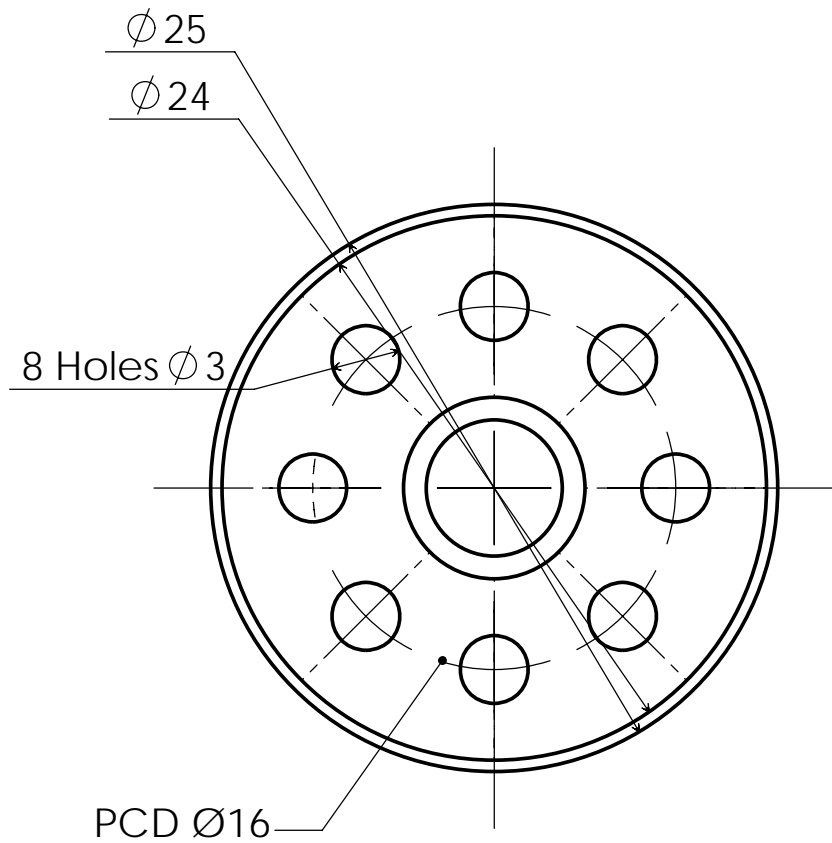

The Cannon	J.C.
PracticalStudent.com	
Part Number : 9	
Part Name : Wheel	
Material : Brass or Steel	A4
Required : 2	2/8/07
Drawing 1 of 1	

Before Starting

Tools for Marking Out :

Tools for Manufacturing :

Skill I am going to concentrate on :

After completion

Marking Accuracy	Poor	Medium	Good
Hacksawing & Filing Quality	Poor	Medium	Good
Surface Finish	Poor	Medium	Good

What did I do well :

What do I need to improve on :

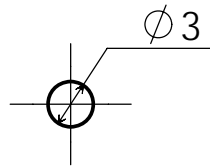
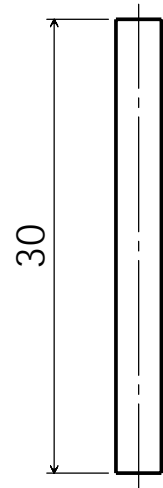

The Cannon	J.C.
PracticalStudent.com	
Part Number : 10 Part Name : Support	
Material : Brass or Steel	A4
	2/8/07
Required : 3	Drawing 1 of 1

Before Starting

Tools for Marking Out :

Tools for Manufacturing :

Skill I am going to concentrate on :

After completion

Marking Accuracy	Poor	Medium	Good
Hacksawing & Filing Quality	Poor	Medium	Good
Surface Finish	Poor	Medium	Good

What did I do well :

What do I need to improve on :

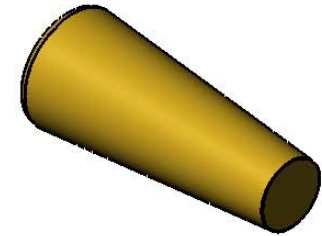
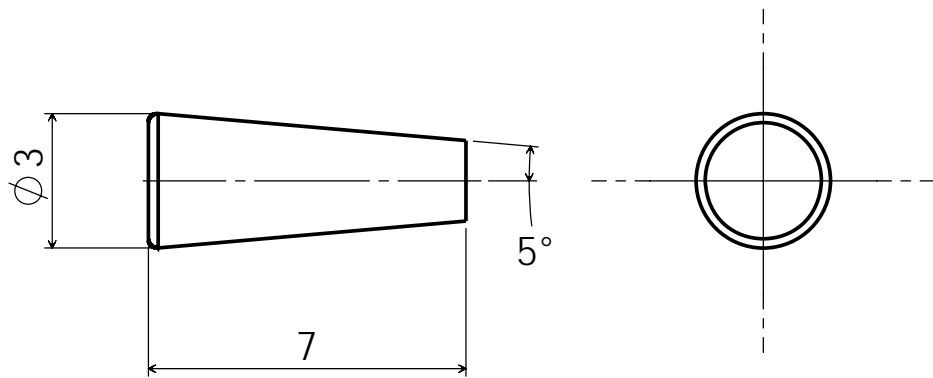

The Cannon	J.C.
PracticalStudent.com	
Part Number : 11 Part Name : Axle Pin	
Material : Brass or Steel	A4
	2/8/07
Required : 2	Drawing 1 of 1

Before Starting

Tools for Marking Out :

Tools for Manufacturing :

Skill I am going to concentrate on :

After completion

Marking Accuracy	Poor	Medium	Good
Hacksawing & Filing Quality	Poor	Medium	Good
Surface Finish	Poor	Medium	Good

What did I do well :

What do I need to improve on :