

Name : \_\_\_\_\_

Part	Complete
1	
2	
3	

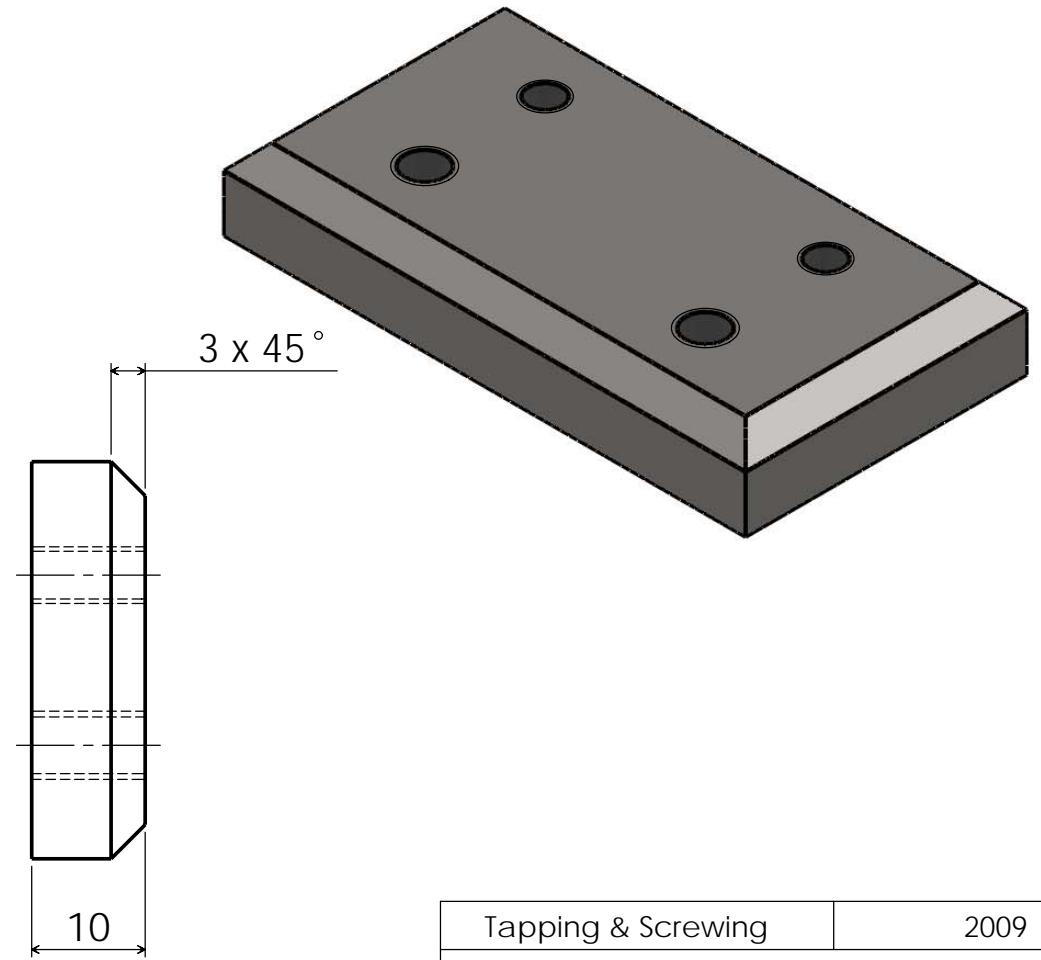

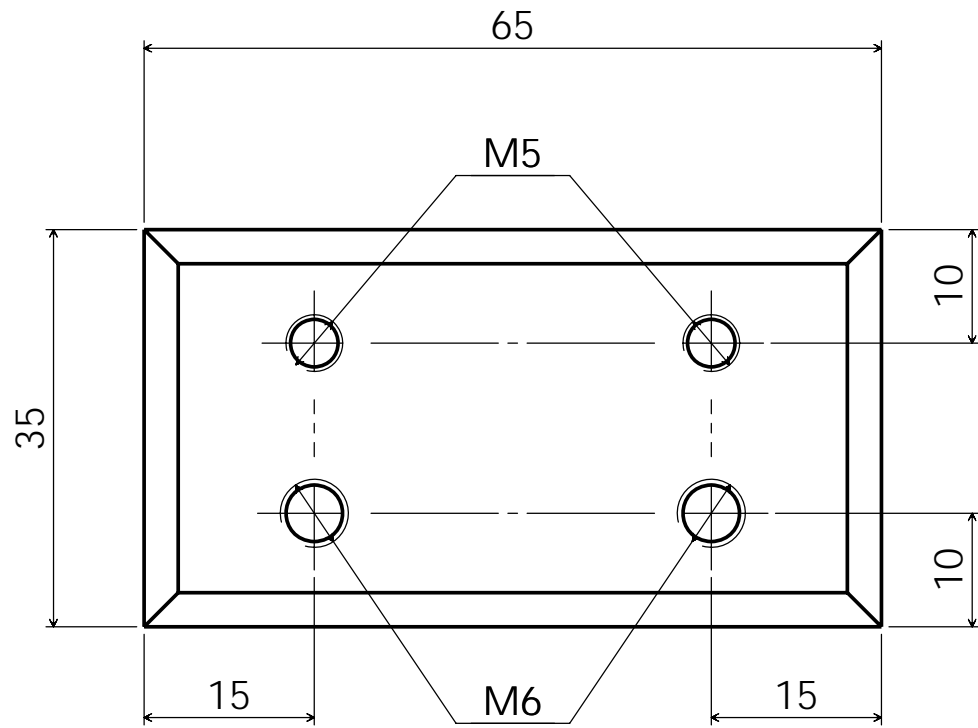

Tapping & Screwing	2009
PracticalStudent.com	
Part Number : 1	
Part Name : Base	
Material : Mild Steel	A4
Required : 1	12/10/09
Drawing 1 of 1	

Before Starting

Tools for Marking Out :

Tools for Manufacturing :

Skill I am going to concentrate on :

After completion

Marking Accuracy	Poor	Medium	Good
Hacksawing & Filing Quality	Poor	Medium	Good
Surface Finish	Poor	Medium	Good

What did I do well :

What do I need to improve on :

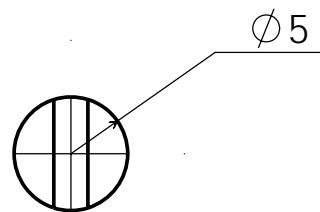
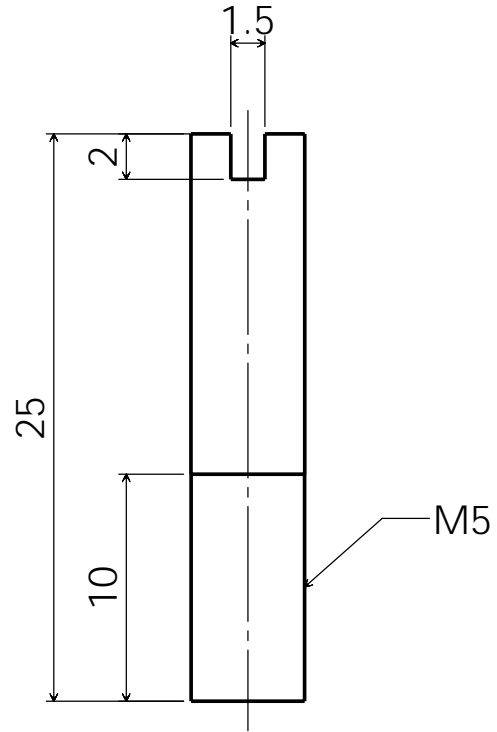

Tapping & Screwing	2009
PracticalStudent.com	
Part Number : 2	
Part Name : M5 Screw	
Material : Mild Steel	A4
Required : 2	15/10/09
Drawing 1 of 1	

Before Starting

Tools for Marking Out :

Tools for Manufacturing :

Skill I am going to concentrate on :

After completion

Marking Accuracy	Poor	Medium	Good
Hacksawing & Filing Quality	Poor	Medium	Good
Surface Finish	Poor	Medium	Good

What did I do well :

What do I need to improve on :

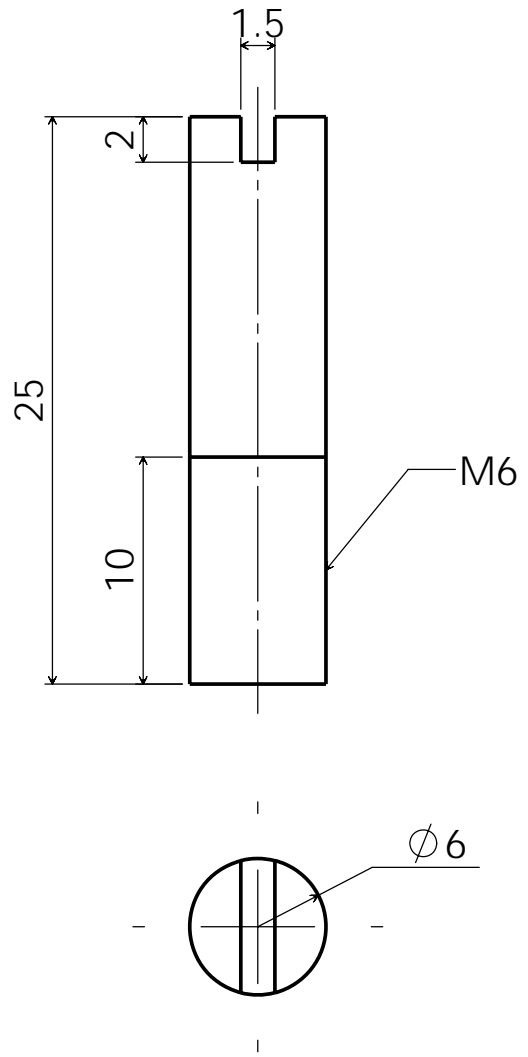

Tapping & Screwing	2009
PracticalStudent.com	
Part Number : 3	
Part Name : M6 Screw	
Material : Mild Steel	A4
Required : 2	15/10/09
Drawing 1 of 1	

Before Starting

Tools for Marking Out :

Tools for Manufacturing :

Skill I am going to concentrate on :

After completion

Marking Accuracy	Poor	Medium	Good
Hacksawing & Filing Quality	Poor	Medium	Good
Surface Finish	Poor	Medium	Good

What did I do well :

What do I need to improve on :